



# USER MANUAL

**BARRETO**

**20hp Hydraulic  
Tracked Trencher**

**Product Code:  
BAR2036TKH-4MS**



Serial Number Range:

From:

To:

Year Of Manufacture: 2018

**\*Please note, when ordering online via our website if the part number is not recognised,  
please Email [spares@hscgroupuk.co.uk](mailto:spares@hscgroupuk.co.uk) or Telephone 0115 946 1988**

**KEEP THIS BOOKLET FOR FUTURE REFERENCE**

Nottingham: 0115 946 1988 • London: 0208 830 3333 ✉ Nottingham: [sales@hscgroupuk.co.uk](mailto:sales@hscgroupuk.co.uk) • London: [sean@hscgroupuk.co.uk](mailto:sean@hscgroupuk.co.uk) 🌐 [www.hscgroupuk.co.uk](http://www.hscgroupuk.co.uk)

The Hire Supply Company Terms & Conditions Apply At All Time E&OE

THE  
**BARRETO**

**MODEL 20RTK – 23RTK**  
**STAND ON HYDRAULIC TRACK TRENCHER**  
**OWNER’S MANUAL**

CONGRATULATIONS!

You are now the proud owner of the BARRETO trencher. The OPERATOR’S MANUAL is attached to the machine. Please study it and this manual to become familiar with the trencher, its characteristics, and method of operation. Pay particular attention to the safety and operating instructions to prevent personal injury or equipment damage.

If you have any questions or need any replacement parts in the future, please contact us at your convenience. Our toll-free phone number, fax and email are listed below.

THANK YOU for your patronage and confidence in BARRETO equipment.

Barreto Manufacturing, Inc.  
Innovative Equipment Engineered to Last  
66498 Hwy 203, La Grande, OR 97850  
(800) 525-7348 (541) 963-7348  
FAX (541) 963-6755  
E-Mail: [info@barretomfg.com](mailto:info@barretomfg.com)  
Web Site: <http://www.barretomfg.com>  
US Patent# 9,988,084

Machine Identification Record

Machine model number \_\_\_\_\_  
Machine serial number \_\_\_\_\_  
Engine manufacturer \_\_\_\_\_  
Engine model number \_\_\_\_\_  
Engine serial number \_\_\_\_\_

# TABLE OF CONTENTS

TRENCHER ASSEMBLY INSTRUCTIONS.....	3
SERVICE INFORMATION .....	3
HOUR METER .....	4
TRENCHER INTENDED USE .....	5
LUBRICATION REQUIREMENTS .....	5
CHAIN INSTALLATION .....	6
OPERATOR TRAINING.....	6
WARRANTY OF BARRETO MANUFACTURING EQUIPMENT .....	7
MAINTENANCE PREPARATION .....	7
ROUTINE MAINTENANCE .....	8
TRACK TENSION ADJUSTMENT .....	9
BATTERY MAINTENANCE .....	10
ELECTRICAL SCHEMATIC - HONDA GX630 & GX690 .....	12
ELECTRICAL SCHEMATIC - BRIGGS/VANGUARD 23 HP.....	13
HYDRAULIC SCHEMATIC .....	14
TRACK TRENCHER TROUBLESHOOTING GUIDE .....	15
SPECIFICATIONS .....	17
INDEX.....	18

# TRENCHER ASSEMBLY INSTRUCTIONS

Upon delivery, check for freight damage and any missing items. If there is damage, notify the carrier and Barreto Manufacturing immediately. Remove trencher from shipping crate.

When documentation refers to “right side” or “left side”, it is relative to the operator’s position while standing on the operator’s stand.

Install cushion pad, boom cushion, and boom. **CAUTION!!** The boom is heavy. Two people should be used to lift it into place. See the exploded view drawing 00368 R1. Push boom on as far as it will go onto the boom mount (part of the chain motor housing weldment). Be sure adjuster screw is backed out.

## SERVICE INFORMATION

### HYDRAULIC SYSTEM:

- Your trencher should arrive with approximately 14 U.S. gallons (53 liters) of tractor transmission / hydraulic fluid in the tank. Shipping regulations may prohibit shipping with the hydraulic fluid. Check the reservoir level using the sight gauge on the side of the tank. If required, add tractor transmission / hydraulic fluid to the reservoir. For machine use in ambient temperatures between +32°F (0°C) and +90°F (32°C) hydraulic fluid ISO 68 is recommended. If the machine is operated at temperatures below +32°F (0°C) then hydraulic fluid ISO 46 is recommended.
- Recheck oil level after trencher has been run and oil has circulated through the components. Routinely check level thereafter.
- Change hydraulic fluid filter after the first 50 hours of use. Change it every 200 hours thereafter.
- Add approximately one quart (1 liter) of hydraulic fluid to reservoir with each filter change.
- Discard the old filter according to environmental standards in your geographic area.
- Check all hydraulic fittings for leaks and tighten if necessary.

**WARNING** - Running the trencher without hydraulic fluid will cause serious damage to the hydraulic pump. **INSURE THAT THE RESERVOIR FLUID LEVEL IS TO THE SIGHT GAUGE BEFORE STARTING THE MACHINE.**

**IMPORTANT: If the couplers between the engine and the pump are moved or removed for any reason, it is CRITICAL that they have a 1/16” gap between them when reinstalled. Failure to have this gap will result in rapid wear and failure of your pump!**

**NOTE: It is very important to move the fuel shutoff lever to the closed position after stopping the engine. Failure to do so could cause fuel to leak down into the cylinder and crankcase. Damage resulting from this will void your engine warranty and not be covered.**

**IMPORTANT** - The engine on the Barreto trencher may or may not have been serviced prior to shipping. Shipping regulations may prohibit shipping with fuel or oil in the engine. Check levels and add oil and fuel as required before starting engine. Service the engine according to the engine owner’s manual before starting.

## HOUR METER

The **DGI® TACH/HOUR** hour meter tracks the hours of machine operation in order for routine maintenance to be performed on a timely basis.

Your **DGI®** hour meter is pre-set at the **DGI®** factory to go into *Flash Alert* mode at 25-hour intervals. Although the engine manufacturer does not require changing engine oil this often, **due to heavy-duty use and extreme conditions inherent to tiller use, Barreto Manufacturing strongly recommends frequent oil changes.**

Refer to this manual for equipment service requirements and to the **Engine Manual** for other engine service requirements.

While *Flash Alert* is active, hold the tip of the RESET TOOL (Key Kancel Wand) against the meter as shown. Within several seconds, the display will stop flashing indicating the Service Interval has been reset. If the wand gets lost, a small mechanic's pick-up magnet will work.

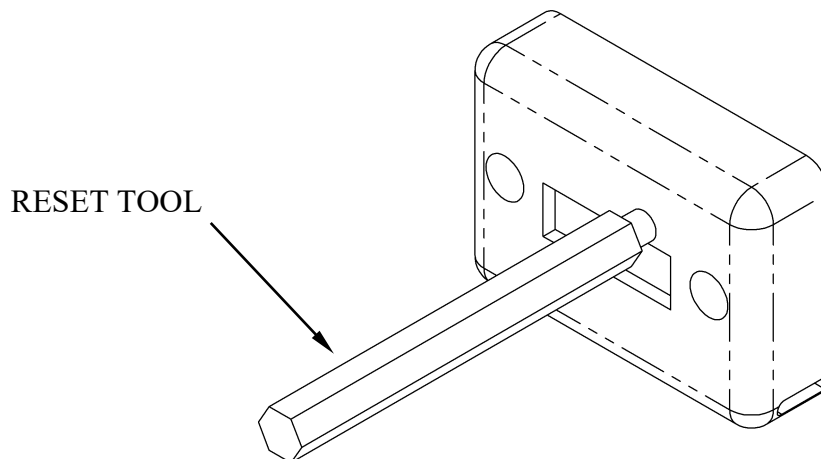

## TRENCHER INTENDED USE

This machine is designed for digging trenches in “normal” ground of reasonably soft dirt and stones up to 6” (15cm) in diameter. Ground with larger stones, high clay content, very hard packed, very dry, or in a frozen condition may be unsuitable for normal trenching. Consider using a backhoe or other heavier equipment for such conditions.

## LUBRICATION REQUIREMENTS

Grease at the intervals indicated per the illustration of grease lubrication points. There is also a grease diagram decal on the machine.

Grease at the intervals indicated:

1. Track rear idlers weekly, or every 30 hours of use.
2. Track front rollers weekly, or every 30 hours of use.
3. Head pivot weekly, or every 30 hours of use.
4. Boom cylinder trunion (both sides) weekly, or every 30 hours of use.
5. Boom cylinder rod end every 12 hours of use.
6. Spindle daily, or every 6 hours of use.
7. Boom slider (both sides) weekly, or every 30 hours of use.
8. Dig chain roller daily, or every 6 hours of use.

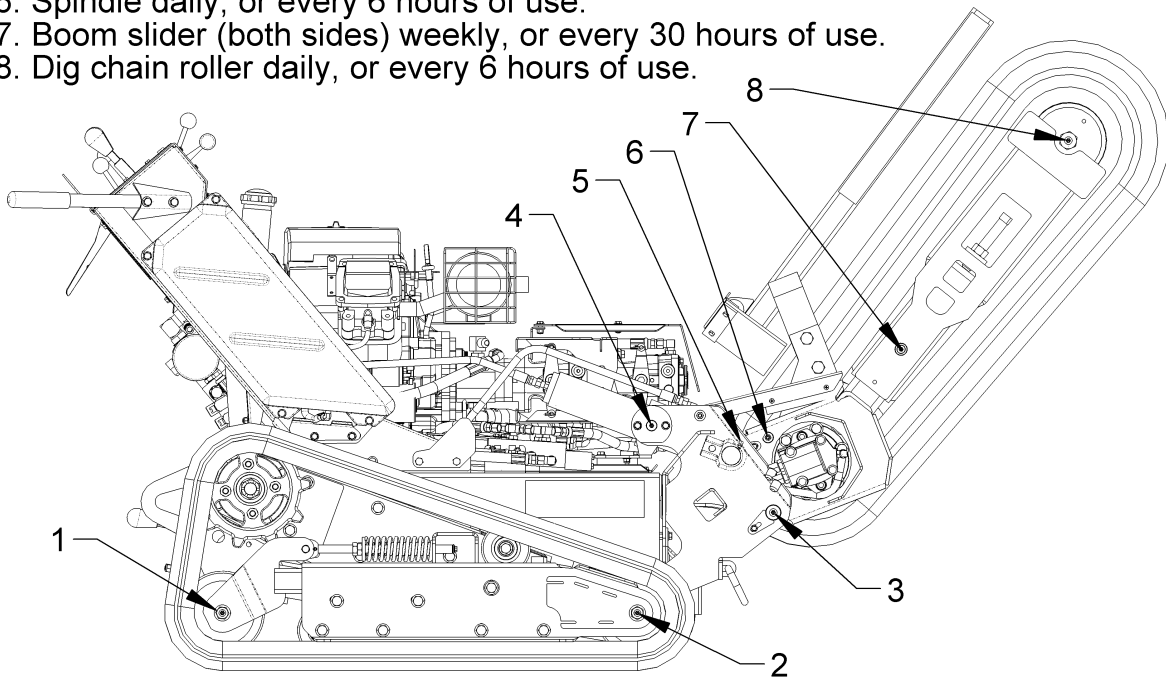

**NOTE: The upright and controls on the RTK trencher will look different than this drawing but the grease points and frequency will be the same.**

## CHAIN INSTALLATION

**CAUTION!!** The chain is quite heavy. You may want help to lift it.

1. Slide chain under sprocket, with teeth in the correct cutting direction. Properly installed, the cutting edges of the chain will face forward on the top of the boom and rearward on the bottom of the boom (see diagram below).
2. Start engine and push digging boom control lever forward to lower boom onto the chain. Stop engine.
3. Wrap chain around boom and sprocket. Install chain master link or link pin and cotter.
4. Use boom adjuster screw to tighten chain. Chain should have enough slack to allow approximately 2" (5cm) of space between middle of boom and chain when boom and chain are straight out in a horizontal position. Tighten adjuster screw locknut.

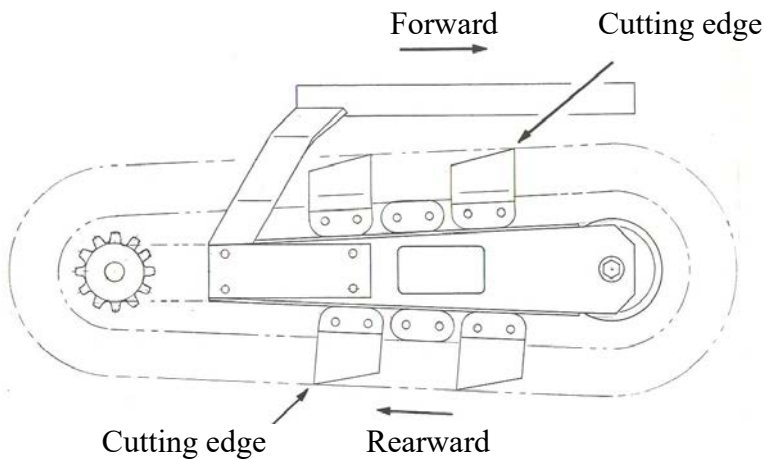

## OPERATOR TRAINING

Rental companies should demonstrate all of the machine operations to each rental customer including:

- Starting up the engine.
- Loading the trencher onto the trailer and securing it for road transport.
- Unloading the trencher from the trailer.
- Trenching procedure - Operation of the trencher.

# WARRANTY OF BARRETO MANUFACTURING EQUIPMENT

Barreto Manufacturing, Inc. warrants all **BARRETO** equipment to be free of defects in material and workmanship for a period of one (1) year. All **BARRETO** fuel components, fuel tank, cap, lines & fittings are warranted for two (2) years. Warranty period begins on date of delivery to the original user. This warranty is in lieu of all other warranties, whether written or implied, and is limited to:

1. Replacement of parts returned to the dealer and/or factory and determined defective upon inspection. (Replacement for parts to dealers shall be at dealer cost plus shipping charges.)
2. Time for pick-up and/or delivery, transportation of service calls by dealers is excluded. Manufacturer reserves the right to determine reasonable time required for repair.

Warranty does not apply to damage caused by abuse or neglect. Time and materials required for normal maintenance and service are also excluded from warranty coverage.

**Engines, engine attached fuel tanks, engine accessories, batteries and tires are warranted by the original manufacturer and are not covered by the Barreto Equipment Warranty.**

**Wear parts such as dig chains, dig teeth, sprockets, chain rollers, bearings, bushings etc. are excluded unless it can be determined that a defect has contributed to premature wear.**

## MAINTENANCE PREPARATION

Only trained & qualified personnel should perform maintenance or repairs of the trencher. Before performing any service, maintenance, adjustments, repairs, or off-season long-term storage, follow the SHUT DOWN PROCEDURE in the OPERATOR'S MANUAL.

Do not touch the engine, muffler, or any of the hydraulic components until cool.



**WARNING:** Muffler and engine get hot enough to cause serious burns.

For the safety of yourself and others, allow enough time for the engine, muffler, and the hydraulic fluid to cool completely before performing any cleaning or maintenance.



Avoid contact with hydraulic fluid.



**WARNING:** When machine is operating, hydraulic fluid is under extreme pressure and can get under skin and burn or poison.

Read the BATTERY & ELECTRIC STARTER SAFETY INSTRUCTIONS. Disconnect the battery, removing the negative terminal first by loosening the wing nut where the cable end is secured to a post on the trencher frame. When ready to reattach the cables, reconnect the positive terminal first.

If you need to lower the dig chain boom without power, do the following:

1. Position a pan under the trencher to catch hydraulic fluid.
2. Support the boom front end with a hoist or forklift.



**WARNING:** The boom with dig chain is heavy. Manpower alone is not recommended, but if necessary, use a team of two strong workers to support the boom, and a third worker to loosen the hose.

3. Loosen the hose at the rod end (front) port of the boom cylinder and lower the boom.
4. If it still will not lower, then loosen the hose at the back end port of the boom cylinder.



## ROUTINE MAINTENANCE

Routinely check the condition, clean, tighten, repair, or replace as necessary the following:

- Dig chain boom guard
- Muffler guard
- Hydraulic hoses and fittings
- Fuel lines
- Fasteners
- Safety decals

Clean safety decals often using soap and water. **Do not use** abrasive cleaners or solvents such as mineral spirits that may damage the decals. Replace any damaged (unreadable) or missing decals. If you replace a machine part that has one or more decals affixed to it, replace the decals also. Replacement parts and decals can be purchased from Barreto Manufacturing, Inc. When attaching decals, the temperature of the mounting surface must be at least 40°F (5°C) and must be clean and dry.

Service the engine according to the engine owner's manual. Follow the directions for all aspects of service including air filter change, oil level checking, filling, draining, disposal of engine oil, disposal of petrol/gasoline, and off-season long-term storage.

Off-season long-term storage of the trencher can be at any ambient temperature.



## TRACK TENSION ADJUSTMENT

Track must be tensioned enough to prevent de-tracking. Too much tension will cause increased wear on roller, sprockets and drive motor bearings. There are two methods of measuring correct tension: Measure the compression of the springs, or measure track sag.

To measure spring compression:

Loosen tension adjuster nut and lock nut completely. Measure free length of springs. Then tighten adjuster nut to compress tension spring pair to a length of 5/8" (16mm) less than free length. Tighten lock nut.

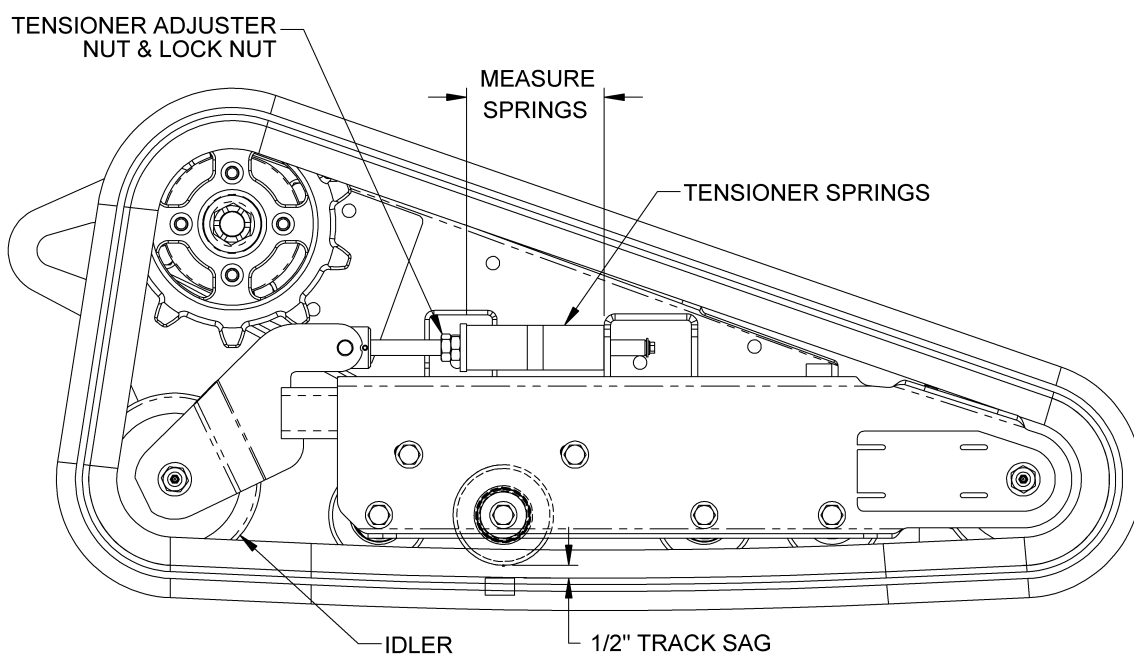

To measure track sag:

Lift the machine and raise the track off the ground. Measure the distance between either one of the central rollers and track metal core bars and adjust track tension to get 1/2" (13mm) track sag.

To remove/replace track:

1. Completely loosen tensioner nuts.
2. Retract idler completely.
3. Remove track from idler first, sprocket second, and front roller last.
4. Reverse procedure to replace track.

Adjust track tension per instructions and illustration.

## BATTERY MAINTENANCE

Follow the SHUT DOWN PROCEDURE in the OPERATOR'S MANUAL before doing any battery maintenance. For your safety always abide by the following:

Shield entire face, especially your eyes, and wear rubber gloves to avoid acid burns whenever doing anything with the battery. Battery caps must be tightly in place if the battery has removable caps.



**WARNING:** The battery contains sulfuric acid that can cause blindness and severe burns. Avoid contact with eyes, skin, and clothing. If acid contacts eyes, call 911 immediately and flush eyes with water for 15 minutes or until emergency medical help arrives. If acid contacts skin, flush area with plenty of water. If acid is ingested, drink large quantities of water or milk then follow with milk of magnesia, beaten egg, or vegetable oil, and get medical attention immediately.

Avoid contact with battery components. Wear rubber gloves and wash hands after handling any battery components.



**WARNING:** Battery posts, terminals, and related accessories contain lead and lead compounds, chemicals known to cause cancer and reproductive harm. Acid can cause blindness and severe burns if leaked from the battery.

Do not charge or jump-start the battery near flames or sparks, or while smoking.



**WARNING:** Battery fumes are flammable and explosive. Avoid explosion hazard that could blind and burn. Tools and jumper cable clamps can make sparks, so use them with care. Shield eyes and face, and wear rubber gloves.

**ELECTROLYTE LEVEL:** Check the battery electrolyte level every 25 hours of machine use and if necessary add distilled water following this procedure:

1. Disconnect the battery cables, removing the negative cable first.
2. Remove the battery from the trencher.
3. Clean the battery exterior with paper towels.
4. If the battery posts and cable terminals are corroded, clean them with a wire brush cleaner tool. A solution of four parts water and one part baking soda is helpful.
5. Apply a light coating of grease to the battery terminals to help prevent corrosion.
6. Remove the battery caps.
7. Slowly pour distilled water into each battery cell until the electrolyte level is up to the full line indicated for each cell on the battery. **Do not overfill.** Overflow of electrolyte, which contains sulfuric acid, can cause severe corrosion to the trencher.
8. Reinstall the battery caps tightly in place.
9. Reinstall the battery securely into the trencher.
10. Reconnect the cables. Attach the positive cable first, then the negative one.

## BATTERY MAINTENANCE (continued)

**BATTERY VOLTAGE LEVEL:** Check the voltage level using an appropriate meter. Always keep the battery fully charged and clean to help prolong battery life expectancy, especially when the temperature is below 32°F (0°C). For off-season long-term storage, we recommend removing the battery from the trencher and storing where the ambient temperature remains above freezing.

**TO CHARGE THE BATTERY** follow this procedure:

1. Disconnect the battery cables, removing the negative cable first.
2. Remove the battery from the trencher.
3. Clean the battery exterior with paper towels.
4. If the battery posts and cable terminals are corroded, clean them with a wire brush cleaner tool. A solution of four parts water and one part baking soda is helpful.
5. Apply a light coating of grease to the battery terminals to prevent corrosion.
6. Check the battery electrolyte level (see procedure above).
7. Insure that the battery caps tightly in place.

Do not charge the battery near flames or sparks, or while smoking.



**WARNING:** Battery fumes are flammable and explosive. Avoid explosion hazard that could blind and burn. Tools and jumper cable clamps can make sparks, so use them with care. Shield eyes and face, and wear rubber gloves.

8. Connect a 12-volt DC battery charger and charge at 3 to 4 amperes for 4 to 8 hours. Do not overcharge.
9. When the battery is fully charged, turn off and unplug the charger from the electrical outlet, then disconnect the charger leads from the battery posts.
10. Reinstall the battery securely into the trencher.
11. Reconnect the cables. Attach the positive cable first, then the negative one.

# ELECTRICAL SCHEMATIC - HONDA GX630/GX690

**2.7 A Charge Coil and With Control Box Type**

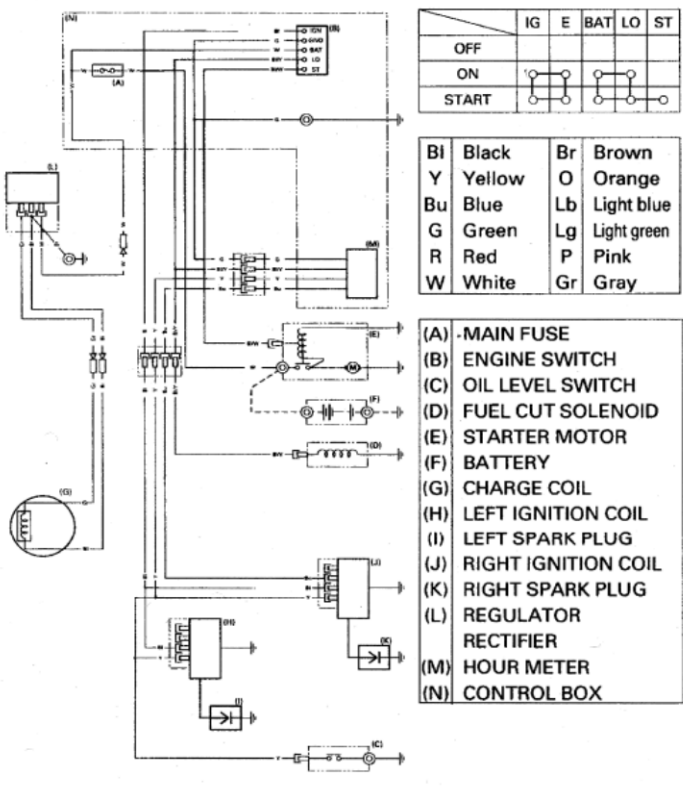

**17 A Charge Coil and With Control Box Type**

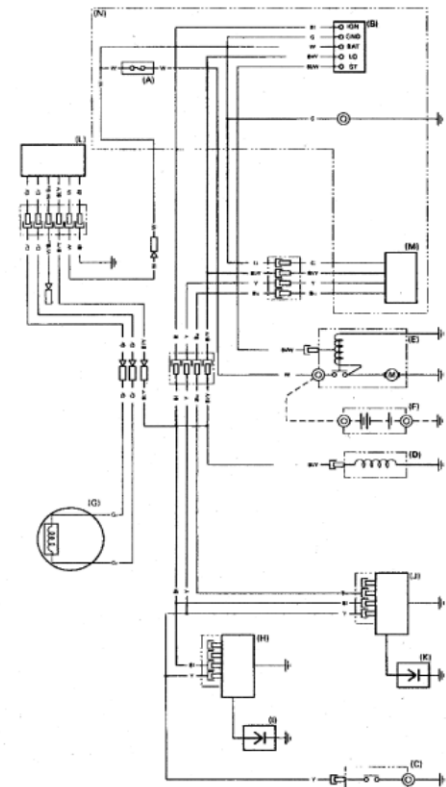

**2.7 A Charge Coil and Without Control Box Type**

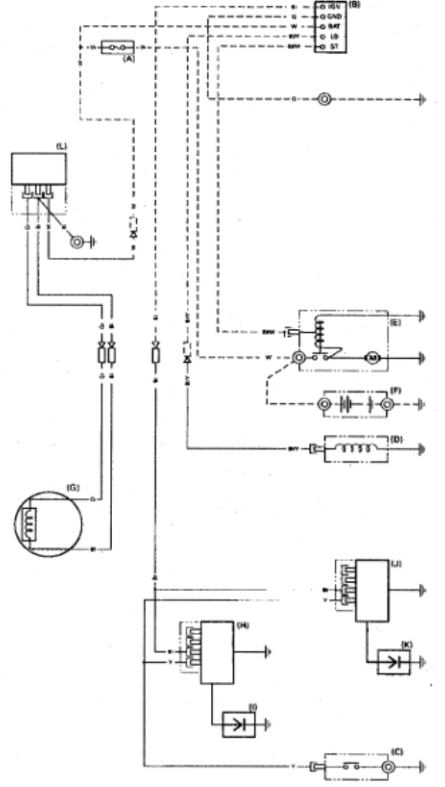

**17 A Charge Coil and Without Control Box Type**

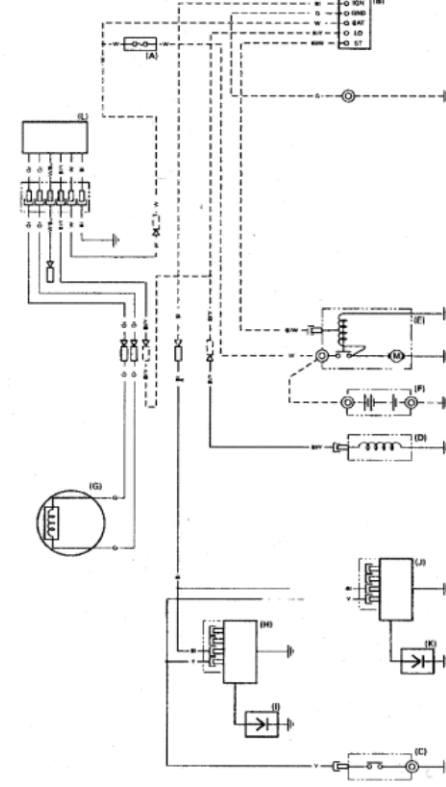

# ELECTRICAL SCHEMATIC – BRIGGS/VANGUARD 23 HP

## Typical Regulated Wiring Diagram

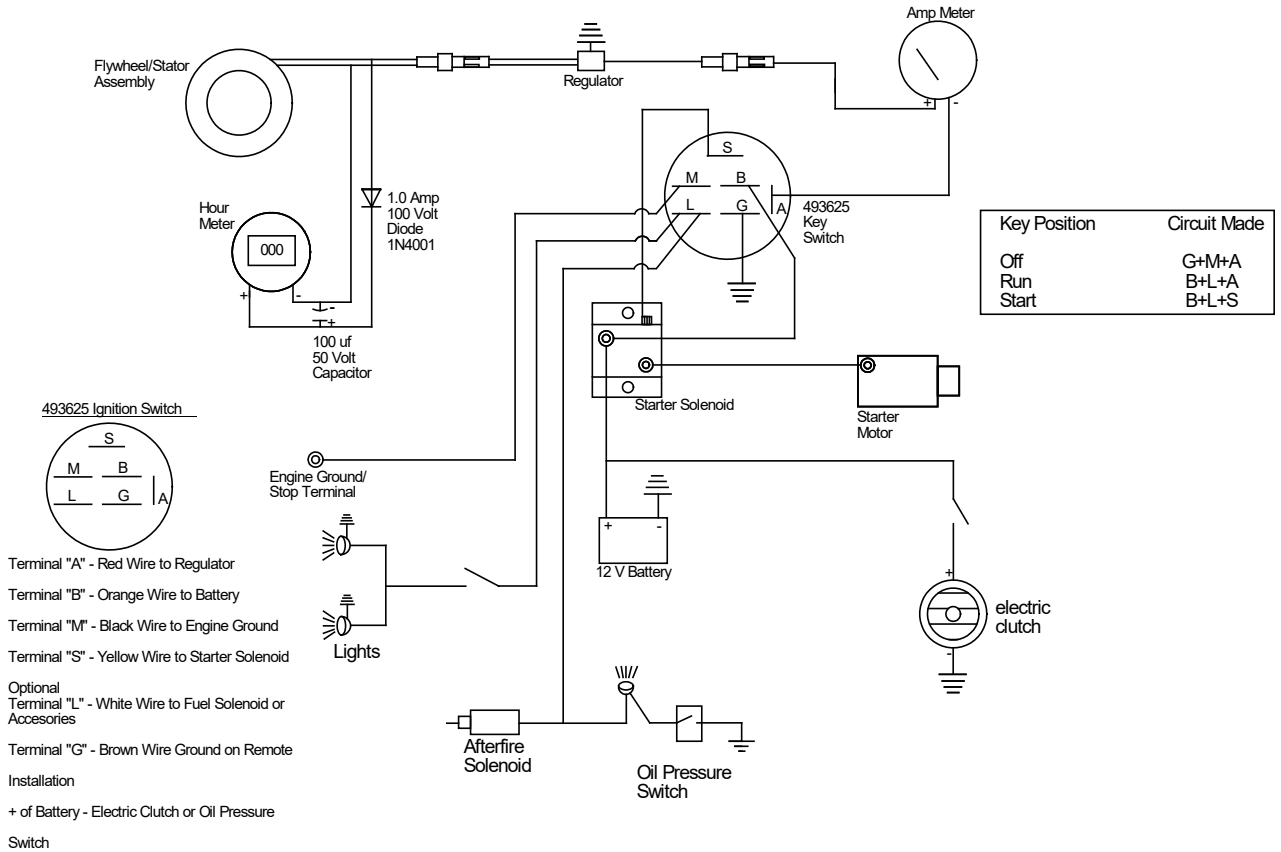

# HYDRAULIC SCHEMATIC

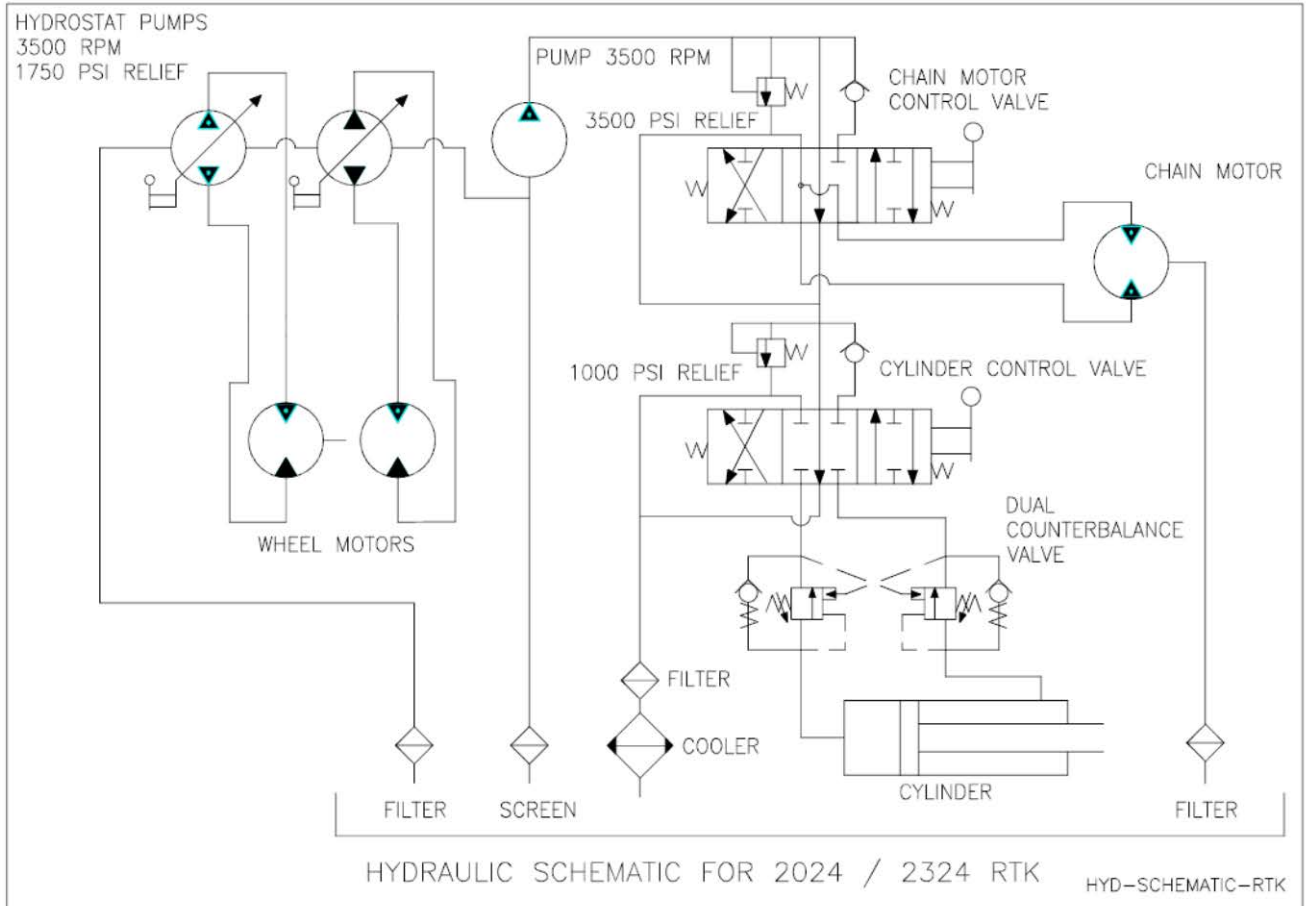

## TRACK TRENCHER TROUBLESHOOTING GUIDE

**CAUTION!!** Always use extreme care when troubleshooting or making adjustments on trencher. Stay clear of chain and auger when engine is running. Stop engine before disassembling any component.

### **A. Entire hydraulic system does not operate and the engine is not under load.**

- |  |  |
|--|--|
| 1. Low hydraulic fluid in tank.                    | Add hydraulic fluid until it shows in sight gauge.                           |
| 2. Hydraulic pump-to-engine coupler has slipped.   | Check for wear and replace both coupler halves and rubber spider, as needed. |
| 3. Main pump suction leaking air into pump intake. | Check main suction hoses and fittings for leaks and tighten fitting nuts.    |

### **B. Engine lugs down or dies and tracks and chain do not turn.**

- |  |  |
|--|--|
| 1. Rocks or other obstructions stopping chain.             | Reverse chain momentarily to free it from obstruction. Raise boom and stop chain. See if obstruction can be removed from trench. |
| 2. Trenching depth or speed too great for soil conditions. | Decrease ground speed or trenching depth.  |
| 3. Engine improperly tuned or maintained.                  | See engine manual and correct as needed.   |
| 4. Low oil alert causes engine to shut down.               | This may occur when trenching on hills. Level trencher, check oil and allow oil alert to reset.                                  |
| 5. Engine losing power due to wear.                        | See engine manual.   |

### **C. Chain fails to rotate, but track drive works.**

- |   |  |
|---|--|
| 1. Chain motor worn.                          | Rebuild or replace motor. New motors are available from Barreto Manufacturing. |
| 2. Chain Control Relief Valve malfunctioning. | Adjust Relief Valve to 3500 PSI or replace relief spring if needed.            |
| 3. Chain drive pump worn.                     | Replace pump.  |



## TRACK TRENCHER TROUBLESHOOTING GUIDE (continued)

### **D. Tracks fail to turn, but chain rotates.**

- |                                     |  |
|-------------------------------------|--|
| 1. Sprocket key sheared.            | Replace key and other parts as needed. |
| 2. Pump cable lever loose on shaft. | Tighten setscrew on pump lever.        |

### **E. Hydraulic fluid leaks in hydraulic system.**

- |   |  |
|---|--|
| 1. Fittings are loose.                          | Tighten fittings on hoses and adapters.  |
| 2. Worn or broken hoses.                        | Replace damaged hoses.   |
| 3. Hydraulic fluid around chain motor or shaft. | Inspect motor for leaking shaft seal. Rebuild or replace motor. New motors are available from Barreto Manufacturing. |

### **F. Foaming hydraulic fluid coming from breather hose.**

- |                           |   |
|---------------------------|---|
| 1. Improper fluid used.   | Verify that hydraulic fluid used had antifoaming additives. Tractor transmission / hydraulic fluid ISO 68 is recommended for use in temperatures above +32°F. |
| 2. Air leaking into fluid | Inspect and tighten fittings and clamps on pump intake hoses  |

### **G. Boom does not lift, or does not lower into ground.**

- |   |  |
|---|--|
| 1. Boom lift relief valve malfunctioning.         | Adjust relief to 1000 PSI. This may require a replacement spring in valve. |
| 2. Boom cylinder piston seal damaged or rod bent. | Disassemble & replace parts as required.                                   |
| 3. Boom pivot bushing seized.                     | Disassemble, inspect, clean & replace parts as required.                   |

## SPECIFICATIONS

### MODEL NUMBERS

**20RTK**

**23RTK**

### DIMENSIONS

Weight	1690 lbs. (766.6 kg)	1690 lbs. (766.6 kg)
Height	56.2" (1.44 m)	56.2" (1.44 m)
Length	108" (2.775 m)	108" (2.77 mm)
Width	35.5" (901.7 mm)	35.5" (901.7 mm)

### ENGINE

Engines	Honda GX630	Briggs 23 hp V-Twin Honda GX690
Fuel	Gasoline	Gasoline
Power: hp (kW) at 3600 RPM	H-20.8 hp (15.52 kW)	B-23 hp (17.2 kW) H-22.1 hp (16.49 kW)
Fuel Capacity	3.2 U.S. gallons (12.1 liters)	3.2 U.S. gallons (12.1 liters)
Engine Oil Capacity	1.8 quarts (1.7 liters)	B-1.4 quarts (1.3 liters) H-1.8 quarts (1.7 liters)
Electric Start	Standard	Standard
Hour Meter	Standard	Standard

### HYDRAULIC SYSTEM

Reservoir Capacity	14 U.S. gallons (53 liters)	14 U.S. gallons (53 liters)
Oil Cooler	Standard	Standard

### TRACK SYSTEM

Track Width	7.1" (180 mm)	7.1" (180 mm)
Total Ground Contact	482.8" (.312 sq/m)	482.8" (.312 sq/m)

### OPERATIONS

Ground Drive, Forward	210 feet per minute (64.8 m/m)	210 feet per minute (64.8 m/m)
Ground Drive, Reverse	90 feet per minute (27.4 m/m)	90 feet per minute (27.4 m/m)

### BOOM / CHAIN OPTIONS

Depths	24, 30, 36, or 42" (61, 76, 91, or 107cm)	24, 30, 36, 42, or 48" (61, 76, 91, 107, or 122cm)
Widths	4" (102mm) or 6" (152mm)	4" (102mm) or 6" (152mm)
Chain Types	Cup, Double Cup, Welded Shark, Bolted Shark, Shark Combo	Skip Cup, Double Cup, Welded Shark, Bolted Shark, Shark Combo

### ACCESSORIES

A1570 - Lift eye: for hoisting the trencher

A1575 - Auxiliary Auger: extends removal of dirt to farther from the side of the trench

A1580 - Backfill blade: to fill in trenches

A1390 - Crumber: provides more effective removal of dirt from trench

Optional on 24, 30, or 36"  
Standard on 42"

Optional on 24, 30, or 36"  
Standard on 42" & 48"

## INDEX

ASSEMBLY INSTRUCTIONS, 3  
BATTERY MAINTENANCE, 10, 11  
BOOM, 3, 6, 7, 15  
CHAIN INSTALLATION, 6  
DECALS, 8  
ELECTRICAL SCHEMATIC – BRIGGS/VANGUARD, 13  
ELECTRICAL SCHEMATIC - HONDA GX630/GX690, 12  
GREASE, 5  
HOUR METER, 4  
HYDRAULIC FLUID, 3, 7, 15, 16  
HYDRAULIC OIL FILTER, 3  
HYDRAULIC SCHEMATIC, 14  
LUBRICATION, 5  
MAINTENANCE, 7, 8  
OPERATOR TRAINING, 6  
SERVICE, 3  
SPECIFICATIONS, 17  
TRACK TENSION ADJUSTMENT, 9  
TRAILER, 6  
TRANSPORT, 6  
TRENCHER INTENDED USE, 5  
TROUBLE SHOOTING, 15, 16  
WARRANTY, 7



## Recycling



**ENVIRONMENTAL PROTECTION:** Please recycle any unwanted materials as opposed to disposing them as general waste. It is recommended the original is retained and used to store the product when not in use for prolonged periods of time. If this is not applicable ensure the materials are sorted and recycled in accordance with local regulations.



**SPECIFICATION CHANGE:** It is our policy to continually improve products to ensure these meet the rigours of the industry we serve. Therefore, as such we reserve the right to alter specifications, data, components & parts with-out prior notice.

**WARRANTY:** Please refer to the manufactures terms & conditions.

**IMPORTANT:** No liability will be accepted for the incorrect use of this product.

### KEEP THIS BOOKLET FOR FUTURE REFERENCE

📞 Nottingham: 0115 946 1988 • London: 0208 830 3333    ✉ Nottingham: [sales@hscgroupuk.co.uk](mailto:sales@hscgroupuk.co.uk) • London: [sean@hscgroupuk.co.uk](mailto:sean@hscgroupuk.co.uk)    🌐 [www.hscgroupuk.co.uk](http://www.hscgroupuk.co.uk)

The Hire Supply Company Terms & Conditions Apply At All Time E&OE